



Environmental Utilities
 2190 Brier Park Pl NW
 Medicine Hat, Alberta T1C 1S6
 Phone: 403.529.8176
 Fax: 403.525.8624
 E-mail: eu@medicinehat.ca
www.medicinehat.ca

COMMERCIAL SOLID WASTE COLLECTION SERVICE REQUEST

UTILITY ACCOUNT INFORMATION

| | |
|-----------------------|---------------------------|
| Business Name: | Business Address: |
| Contact Name: | Alternate Contact: |
| Phone #: | Alternate Phone #: |

BIN SIZE DIMENSIONS

| Bin Size | Dimensions – height x depth x width |
|---|-------------------------------------|
| 1.5 cubic yard bin | 50" x 28" x 56" |
| 3.0 cubic yard bin (both solid waste and cardboard) | 57" x 45" x 56" |

BIN SIZE REQUESTED

PICK UP FREQUENCY REQUESTED

| | |
|---|--|
| <input type="checkbox"/> 1.5 cubic yard garbage bin | <input type="checkbox"/> 1 pick up/week |
| <input type="checkbox"/> 3.0 cubic yard garbage bin | <input type="checkbox"/> 2 pick ups/week (max for cardboard p/u) |
| <input type="checkbox"/> 3.0 cubic yard cardboard bin | <input type="checkbox"/> 3 pick ups/week |
| | <input type="checkbox"/> 4 pick ups/week |
| | <input type="checkbox"/> 5 pick ups/week |

PREFERRED PICK UP DAY(S)

Monday Tuesday Wednesday Thursday Friday

Comments:

CUSTOMER AUTHORIZATION

Signature _____

Date _____

Please complete, sign and email or fax the Service Request Form using the above noted contact details.

Commercial Solid Waste Collection Service

The Solid Waste Utility offers waste collection services to commercial, industrial and institutional businesses within the city. To help us provide you with safe, efficient and environmentally sound solid waste collection services, the Environmental Utilities Department requests that commercial account customers follow the collection guidelines as outlined.

- City of Medicine Hat commercial bins are side-load only.
- Minimum collection level is one pickup per week. Collection frequency can range up to five days per week.
- The minimum service period is four months. If service is discontinued prior to four months, accounts will be charged a fee for bin removal.
- Requests for additional pickup will be billed to the utility account as a separate charge.
- Do not place items such as boxes, pallets, other debris or excess garbage around or on top of commercial containers. Additional material should be held until your next collection day.
- Appliances, furniture, tires, batteries, paint, hazardous liquids and materials, medical waste etc. is **NOT** accepted for collection. Contaminated containers may be refused service or charged a fee for load contamination.
- Keep container lids closed at all times to avoid any debris blowing out and to contain odours. Please do not overload to the extent that the lid cannot close.
- If the collection container is locked or enclosed by a gate, please have the container accessible **by 6 a.m. on collection day**. If access is unavailable or blocked, the container will not be collected as scheduled.
- If a solid waste operator is required to unlock a container or gate, accounts will be billed a fee as determined by the Solid Waste Utility at time of initial site inspection.
- Service collection that falls on a recognized holiday may occur the day before or after the regular scheduled collection day.
- Container cleaning and maintenance is the account holder's responsibility.

For more information regarding Commercial Solid Waste Collection, please contact the Environmental Utilities Department at 403.529.8176.

City of Medicine Hat Commercial Bin Dimensions

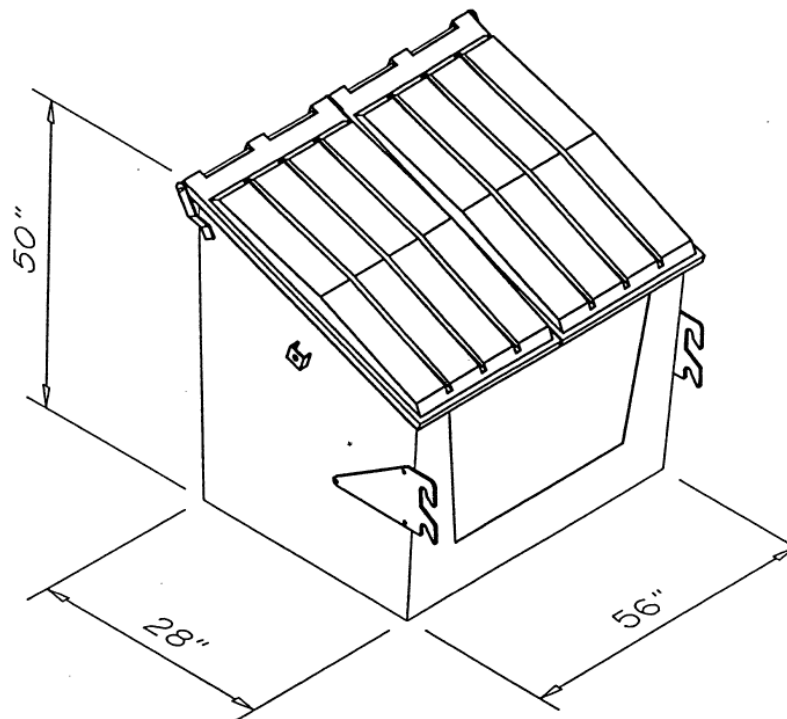

1.5 cu yd Waste Container

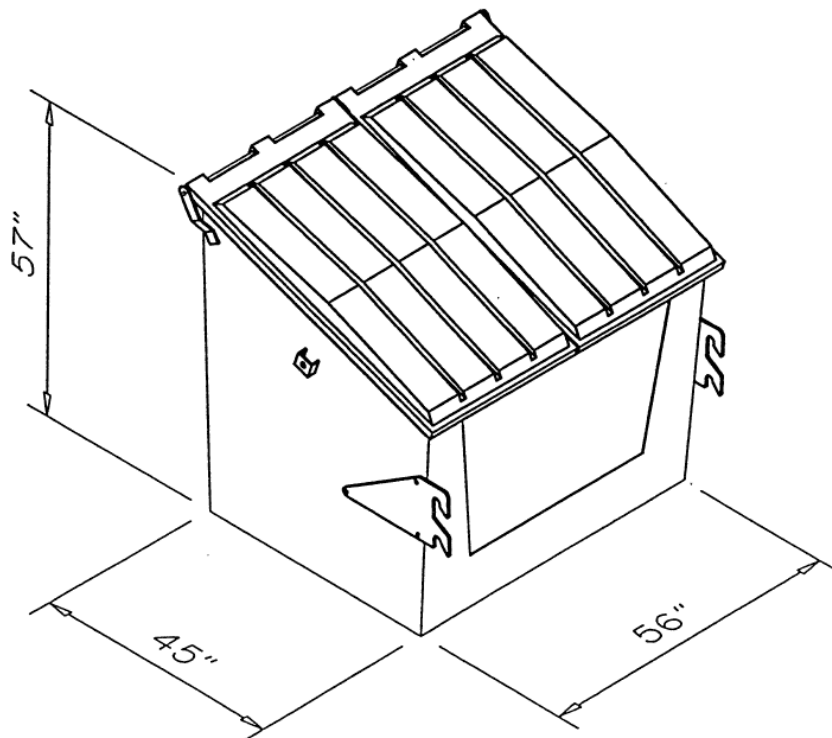

3.0 cu yd Waste Container